

TOSHIBA

TOSHIBA Portable Printer

B-EP2D/EP4D SERIES

Owner's Manual

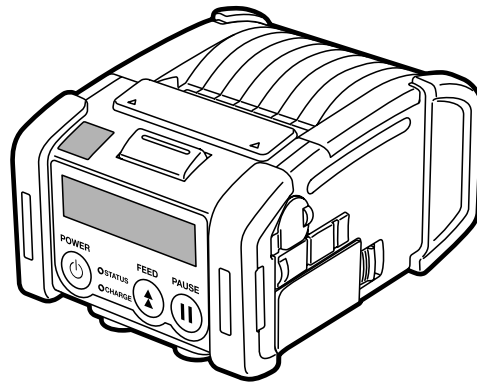

[B-EP2DL]

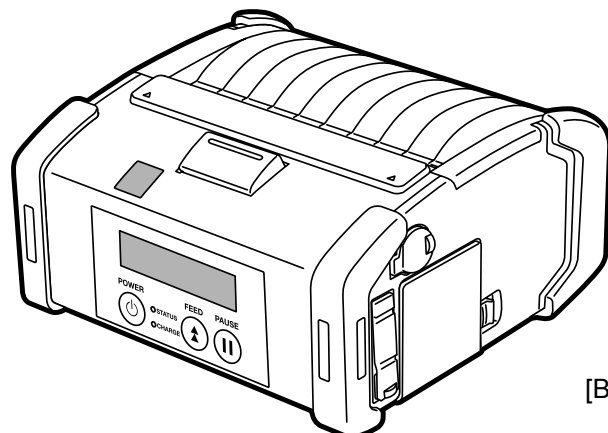

[B-EP4DL]

CE Compliance (for EU only)

This product complies with the requirements of EMC, Low Voltage and R&TTE Directives including their amendments.

FCC Notice

This equipment has been tested and found to comply with the limits for a Class B digital device, pursuant to Part 15 of the FCC Rules. These limits are designed to provide reasonable protection against harmful interference in a residential installation. This equipment generates, uses, and can radiate radio frequency energy and, if not installed and used in accordance with the instructions, may cause harmful interference to radio communications. However, there is no guarantee that interference will not occur in a particular installation. If this equipment does cause harmful interference to radio or television reception, which can be determined by turning the equipment off and on, the user is encouraged to try to correct the interference by one or more of the following measures:

- Reorient or relocate the receiving antenna.
- Increase the separation between the equipment and receiver.
- Connect the equipment into an outlet on a circuit different from that to which the receiver is connected.
- Consult the dealer or an experienced radio/TV technician for help.

"This Class B digital apparatus meets all requirements of the Canadian Interference-Causing Equipment Regulations."

"Cet appareil numérique de la classe B respecte toutes les exigences du Règlement sur le matériel brouilleur du Canada."
(for CANADA only)

VORSICHT:

Maschinenlärminformations-Verordnung 3. GPSGV, der höchste Schalldruckpegel beträgt 70 dB(A) oder weniger gemäß EN ISO 7779.

Some types of this product are equipped with a wireless communication device, such as, TEC-BTM-R and SD-Link 11g. Please be sure to read the enclosed Precautions for Handling of Wireless Communication Devices before using this product.

CAUTION

1. Only use TOSHIBA TEC battery packs designed and manufactured for use with the specific printer model. There is a risk of explosion if the battery is replaced by an incorrect type. Dispose of used batteries according to the instructions.

B-EP2DL-GH20-QM-R	} B-EP802-BT-QM-R	B-EP4DL-GH20-QM-R	} B-EP804-BT-QM-R
B-EP2DL-GH30-QM-R		B-EP4DL-GH30-QM-R	
B-EP2DL-GH40-QM-R		B-EP4DL-GH40-QM-R	

2. When an external power source such as an AC adapter is connected to the printer, DO NOT use any device other than an exclusive one.

AC adapter:	B-EP800-AC-QM-R (Model: 0225A1950)
Cigarette lighter adapter:	B-EP802-DC12-QM-R
DC adapter:	B-EP800-DC48-QM-R

The following information is for EU-member states only:

Disposal of batteries and/or accumulators

(based on EU-Directive 2006/66/EC,

Directive on batteries and accumulators and waste batteries and accumulators)



The use of the symbol indicates that batteries and/or accumulators may not be disposed as unsorted municipal waste and has to be collected separately.

By ensuring that batteries and/or accumulators are disposed of correctly, you will help prevent potential negative consequences for the environmental and human health, which could otherwise be caused by inappropriate waste handling of this product.

For more detailed information about the take-back and recycling of batteries and/or accumulators, please contact your supplier where you purchased this product.



< For EU Only >

TOSHIBA TEC Europe Retail Information Systems S.A.
Rue de la Célidée 33 BE-1080 Brussels

Copyright © 2008

by TOSHIBA TEC CORPORATION

All Rights Reserved

570 Ohito, Izunokuni-shi, Shizuoka-ken, JAPAN

TOSHIBA TEC CORPORATION

E PRINTED IN JAPAN
EO1-33079

Precautions for Handling of Wireless Communication Devices

Bluetooth® Module: TEC-BTM-R (GH30 model)

Wireless LAN Module: SD-Link 11g (GH40 model)

Trade Mark

Bluetooth is a registered trademark owned by Bluetooth SIG, Inc. and used by TOSHIBA TEC CORPORATION under license.

Cautions

General

For all countries and areas

This product is a wireless communication device, and the use of this product is restricted to the following countries or areas. If the product is used in the countries or areas other than the following, you may be punished according to the laws of those countries or areas.

Japan, USA, Canada, Austria, Belgium, Bulgaria, Cyprus, Czech Republic, Denmark, Estonia, Finland, France, Germany, Greece, Hungary, Ireland, Italy, Latvia, Lithuania, Luxembourg, Malta, Netherlands, Poland, Portugal, Romania, Slovakia, Slovenia, Spain, Sweden, United Kingdom, Switzerland, Norway, Iceland, Liechtenstein, Australia, New Zealand, Mexico, China, Korea, Taiwan

For Europe

CE 0682 for Bluetooth **CE 0560** **D** for wireless LAN

Hereby, TOSHIBA TEC CORPORATION, declares that the TEC-BTM-R and SD-Link11g are in compliance with the essential requirements and other relevant provisions of Directive 1999/5/EC. This equipment uses a radio frequency band that has not been harmonized throughout all EU and EFTA countries, and can be used in the following countries. Austria, Belgium, Bulgaria, Cyprus, Czech Republic, Denmark, Estonia, Finland, France, Germany, Greece, Hungary, Ireland, Italy, Latvia, Lithuania, Luxembourg, Malta, Netherlands, Poland, Portugal, Romania, Slovakia, Slovenia, Spain, Sweden, United Kingdom, Switzerland, Norway, Iceland, Liechtenstein

For USA

This device complies with Part 15 of the FCC Rules. Operation is subject to the following two conditions:

- (1) this device may not cause harmful interference, and
- (2) this device must accept any interference received, including interference that may cause undesired operation.

Changes or modification not expressly approved by manufacturer for compliance could void the user's authority to operate the equipment.

For Canada

Operation is subject to the following two conditions:

- (1) this device may not cause interference, and
- (2) this device must accept any interference, including interference that may cause undesired operation of the device.

To prevent radio interference to the licensed service, this device is intended to be operated indoors and away from windows to provide maximum shielding. Equipment that is installed outdoors is subject to licensing.

For safety

Do not use this product in locations where use may be forbidden, for example, in an aeroplane or a hospital. If you do not know the forbidden areas, please refer to and follow the airline company or medical institution guidelines. Flight instrument or medical equipment may be affected, causing a serious accident.

Since this product uses extremely low power compared with mobile phones, it cannot possibly interfere the pacemakers and defibrillators. However, if the use of this product should be likely to have affected the pacemaker or defibrillator, immediately stop using the product and contact your TOSHIBA TEC sales agent.

Do not disassemble, modify, or repair the product. Doing so may cause injury. Also, modification is against the Laws and Regulations for Radio Equipment. Please ask your TOSHIBA TEC sales agent for repair.

Precaution in use

This product communicates with other devices by radio. Depending on the installation location, orientation, environment, etc., its communication performance may deteriorate or devices installed near by may be affected.

Keep away from a microwave.

Communication performance may deteriorate or a communication error may occur due to the radio emitted from a

microwave.

Since the Bluetooth and wireless LAN use the same radio frequency band, each radio wave may interfere with each other when they are used at the same time, causing a deterioration of communication performance or a disconnection of network. If there is any problem with connection, please stop using either Bluetooth or wireless LAN.

Do not use the product on a metal table or near a metal object.
Communication performance may be deteriorated.

TEC-BTM-R Specification

- Bluetooth class 2
- Built-in protocol stack activated by Bluetooth V1.2 serial port profile
- Operating temperature: -5 to 50°C 25% to 85%RH (No condensation)
- Dimensions: 38.1 mm (W) x 25.4 mm (H) x 7 mm (D)

SD-Link 11g Specification

- Built-in IEEE802 Part 11b/g (802.11b/g)
- Operating temperature: 0 to 50°C 25% to 85%RH (No condensation)
- Dimensions: 67.8 mm (W) x 36.8 mm (H) x 7.5 mm (D)

Changes or modifications not expressly approved by manufacturer for compliance could void the user's authority to operate the equipment.

CAUTION!

- 1.To avoid injury, be careful not to catch or jam your fingers while opening or closing the cover.
- 2.Do not touch moving parts. To reduce the risk that fingers, jewellery, clothing, etc., be drawn into the moving parts, turn off the power switch to stop movement.

Safety Summary

Personal safety in handling or maintaining the equipment is extremely important. Warnings and Cautions necessary for safe handling are included in this manual. All warnings and cautions contained in this manual and written inside or outside of the printer should be read and understood before handling or maintaining the equipment.

Do not attempt to effect repairs to this equipment. If a fault occurs that cannot be rectified using the procedures described in this manual, turn off the power, then contact your authorised TOSHIBA TEC representative for assistance.

Safety Precautions

This Owner's Manual and the products (machines) which you have purchased contain indications which should be observed in order to use the machines safely and prevent harm to yourself and others and damage to property. The meanings of these indications and symbols are given below.

Read these indications and become familiar with their contents before reading this Owner's Manual.

Precautions

The following precautions will help to ensure that this machine will continue to function correctly.

- (1) Try to avoid locations that have the following adverse conditions:
 - *Temperatures below -5°C and above 40°C
 - *Humidity below 10%RH and above 90%RH
 - *Direct sunlight
 - *Excessive vibration
- (2) The cover should be cleaned by wiping with a dry cloth or a cloth slightly dampened with a mild detergent solution. NEVER USE THINNER OR ANY OTHER VOLATILE SOLVENT on the plastic covers.
- (3) USE ONLY TOSHIBA TEC SPECIFIED media.
- (4) DO NOT STORE the media where it might be exposed to direct sunlight, high temperatures, high humidity, dust, or gas.
- (5) Any data stored in the memory of the printer could be lost during a printer fault.
- (6) DO NOT open the media cover and battery cover during operation. Doing so will stop printer operation.
- (7) DO NOT scratch the surface of printed labels or receipt with a sharp object.

CAUTION!

- 1.This manual may not be copied in whole or in part without the prior written permission of TOSHIBA TEC.
- 2.The contents of this manual may be changed without notification.
- 3.Please refer to your local Authorised Service representative with regard to any queries you may have in this manual.

**WARNING**

This indicates that there is the risk of death or serious injury if the machines are handled improperly or contrary to this indication.

- If water or any other liquid enters the machine, turn off the power. Continuous use of the machine under such conditions may cause fire or electric shock.
- If the enclosure is damaged when dropped or subject to shock, turn off the power. Continuous use of the machine under such conditions may cause fire or electric shock.
- Avoid continuous exposure to direct sunlight or high temperature as this may cause fire.
- Do not remove covers or modify the machine by yourself. Doing so may cause fire or electric shock.
- Avoid water, operation with wet hands or cleaning with a moistened cloth. Failure to do this may cause fire or electric shock.
- Do not wipe the machine with a cloth moistened with thinner or other volatile solvent as this may cause fire or electric shock.
- Use the specified battery only. Failure to do this may cause fire or electric shock.
- Danger of explosion if the battery is incorrectly replaced. Replace the battery only with TOSHIBA TEC Corporation, Battery Pack Model B-EP802-BT-QM-R 7.4V 2600mAh Li-ion or B-EP804-BT-QM-R 14.8V 2600mAh Li-ion. Discard used batteries according to the manufacturer's instruction.
- Do not disassemble and modify the battery because it has a protection unit in it. Doing so may break the protection unit, causing the battery to heat up, burst or burn.
- If the battery gets wet, dry it completely. Using a wet battery may cause fire or electric shock.

- Be aware of the following precautions when using batteries. Otherwise they could heat up, burst or burn.
 - Do not throw the battery into fire or heat it with a microwave or oven, etc.
 - Do not load the battery with the electrodes reversed.
 - Do not connect the electrodes with metal objects like wire. Do not carry or store the battery along with metal objects such as necklaces, hairpins, etc.
 - Do not stick a needle into, hammer, step on, or drop the battery.
 - Do not solder the battery.
 - Do not leave the battery where the temperature is more than 60°centigrade, such as inside a car or in direct sunlight.

**CAUTION**

This indicates that there is the risk of personal injury or damage to objects if the machines are improperly handled contrary to this indication.

- Keep away from flame or other sources of heat. Failure to do this may cause fire or machine failure.
- Do not drop or shock the machine as this may cause machine failure.
- During lightning, turn off and keep away from the machine because of danger of electric shock and machine failure.
- Avoid locations subject to rapid change in temperature as this causes condensation, causing electric shock or machine failure.
- Do not damage the print head, platen or strip roller with a sharp object. Doing so may cause machine failure.
- Do not touch or contact the print head element with a metal object. Doing so may cause machine failure.
- Use the specified media only. Failure to do this may cause machine failure.
- Be sure to turn off the machine before replacing the battery, or machine failure may occur.
- Do not charge the battery near flame or under direct sunlight. High temperature may activate or damage the protection unit of the battery, disabling the electric charge or causing it to overheat, burst, or burn.
- Unload the battery when the machine will not be used for a longtime. Failure to do this may cause machine failure.
- Keep the battery away from flame, a heat source or other locations subject to high temperature. Failure to do this may cause it to over heat or burn.

- Use the specified battery charger only. Failure to do this may cause the battery to overheat, burst or burn.
- Do not force the battery into the machine or battery charger. Doing so may cause the battery to overheat, burst or burn. Check for the correct electrode.
- Do not connect the battery to a power outlet or a car cigarette lighter jack as this may cause the battery to overheat, burst or burn.
- Because the B-EP802-BT-QM-R and the B-EP804-BT-QM-R Series battery is exclusively for the B-EP2DL and the B-EP4DL Series printer, respectively, do not use the battery in other machines. Doing so may damage the battery or affect the performance and life of the battery.

Part Names

B-EP2DL Series

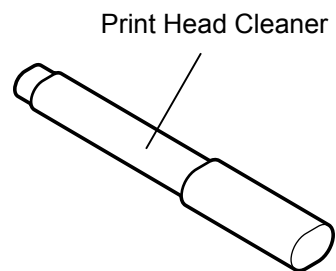
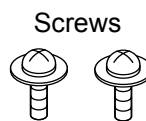
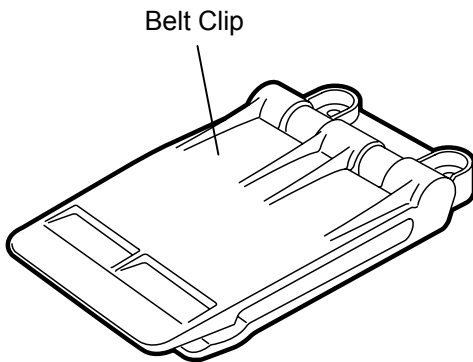
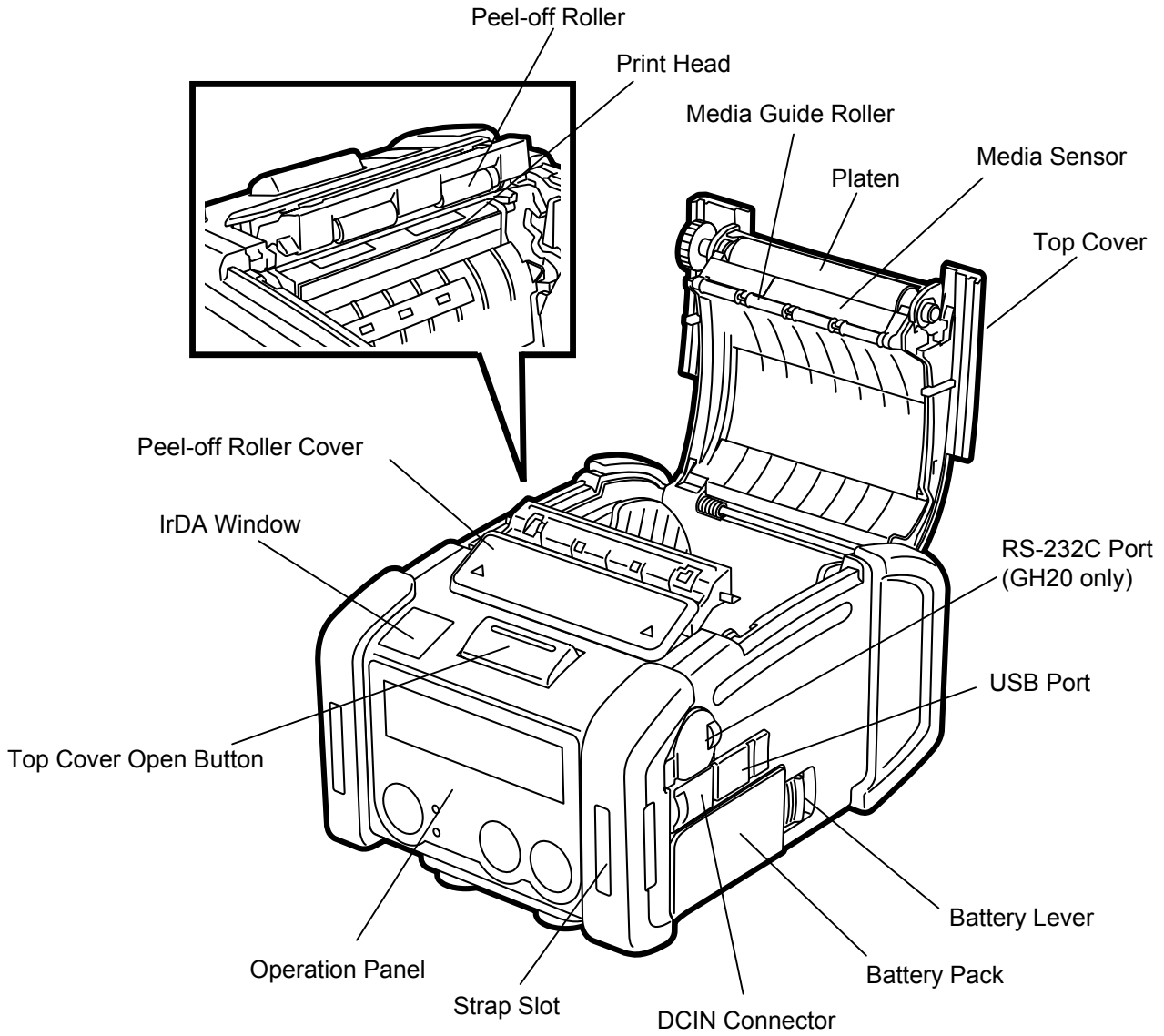

B-EP4DL Series

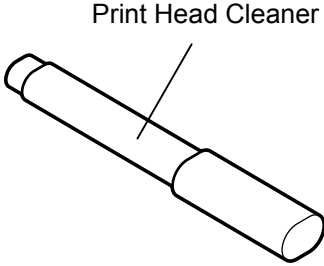
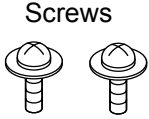
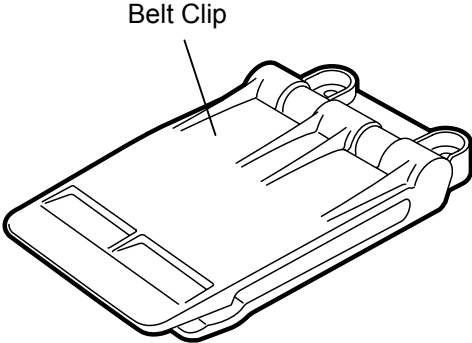
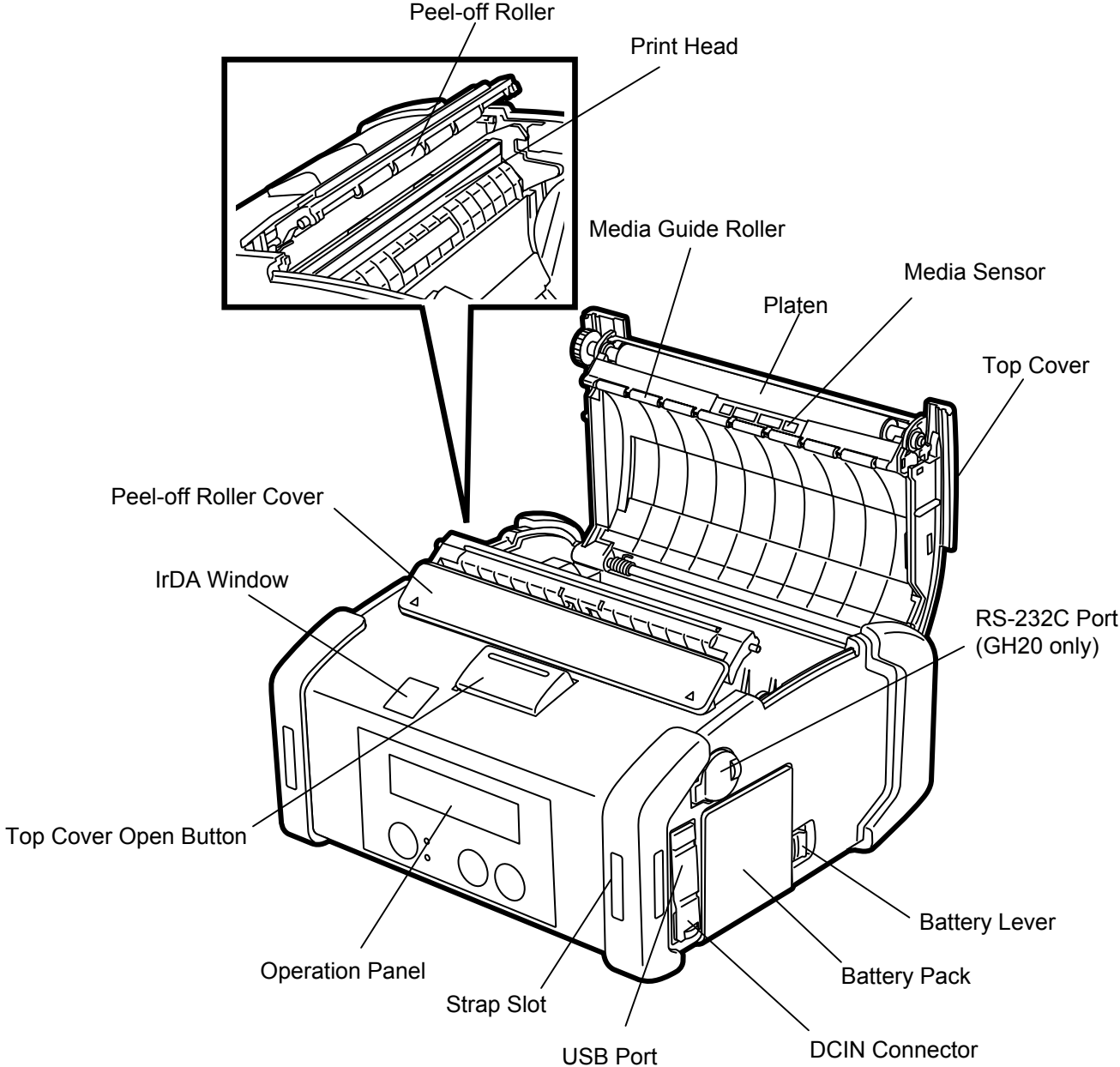

Operation Panel Functions

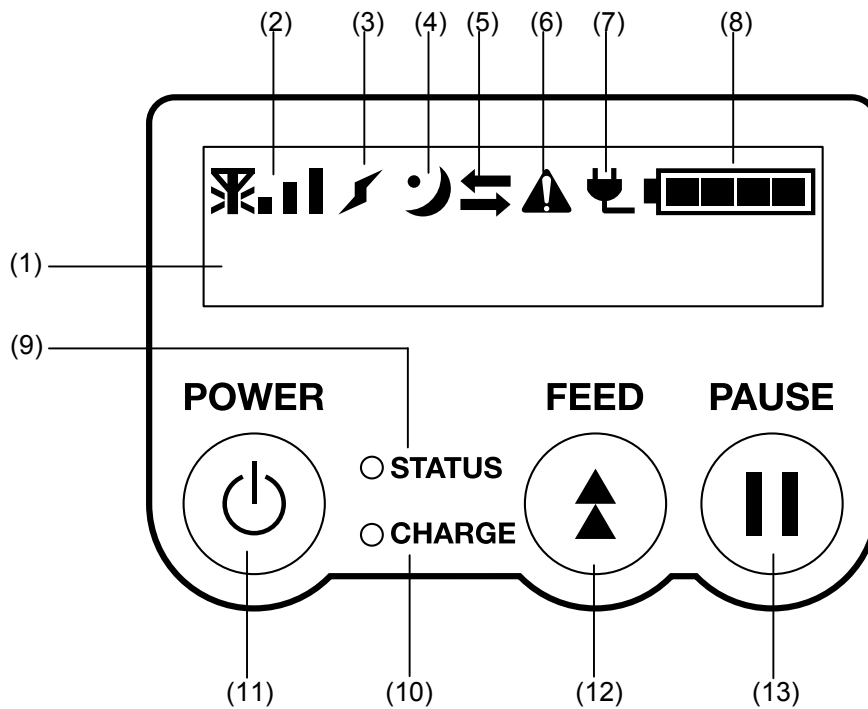

No.	Name/Icon	Function/Usage
(1)	Liquid Crystal Display (16 lines x 2 lines)	Upper line: Icons indicating the printer statuses, such as the radio intensity, battery level, etc. are displayed. Lower line: Printer status is indicated in alphanumerals or symbols.
	LCD Message	ON LINE The printer is ready for an issue command from the host.
		PAUSE The printer is in pause state. When the printer is paused during printing, the number of unprinted labels is displayed.
	COVER OPEN The top cover is open.	
(2)	Radio intensity	Indicates the radio intensity in 4 levels (GH40 only)
(3)	Connection	Indicates an access point connection status (GH40 only)
(4)	Sleep	Displayed while the printer is in the power save mode.
(5)	Transmission	Indicates data transmission status.
(6)	Error	Displayed when an error occurred on the printer.
(7)	External power source	Displayed when the printer is charged with an optional device.
(8)	Battery level	Indicates the battery level in 5 levels.
(9)	STATUS lamp	Lights or blinks in green, red, or orange to indicate the printer status. <ul style="list-style-type: none"> • Lights up in green: Normal state • Lights up in orange: Near a low-battery state (Operable) • Lights up in red: Low-battery state • Blinks in green or orange: Communicating or internal processing is in progress or a printed label is waiting to be removed. • Blinks in red: Error state
(10)	CHARGE lamp	Blinks in orange while the battery pack is charged. Lights up in green when the battery charge is completed.

(11)	[POWER] button	Turns on or off the printer. How to turn on the printer While the printer is off, hold down the POWER button for a few seconds. When "ONLINE" is displayed on the LCD, the printer is ready. How to turn off the printer Hold down the POWER button until the LCD goes off.
(12)	[FEED] button	Feeds media or reprints a previously printed data. Function of the [FEED] button differs depending on the issue mode.
(13)	[PAUSE] button	Temporarily stops media issue or restarts printing. Used to reprint the previous data after an error is cleared.

Loading a battery pack

WARNING!

1. If the battery pack leaks liquid or gives out smoke or bad smell, immediately stop using it and keep it away from fire. Failure to do this may cause explosion or combustion.
 2. In the United States, used lithium ion batteries should be returned to the store where you bought the machine. (USA only)
 3. LITHIUM ION BATTERY DISPOSE OF PROPERLY
- Caution: Do not handle damaged or leaking lithium ion battery.

Pushing aside the Battery Lever with the Battery Pack, insert the Battery Pack into the printer to the bottom. The Battery Pack is locked by the Battery Lever.
Be careful of the orientation of the Battery Pack.

Notice

- Be sure to use a battery pack designed and manufactured for use with the specific model.
B-EP2DL series: B-EP802-BT-QM-R
B-EP4DL series: B-EP804-BT-QM-R
- When unpacked, the battery level of the supplied Battery Pack is not full. Please charge the Battery Pack with an optional Battery Charger or load the Battery Pack in the printer and connect an optional adapter before using it.
 - ◆ Single-slot Battery charger: B-EP800-CHG-QM-R
 - ◆ 6-slot Battery Charger: B-EP800-CHG6-QM-R
 - ◆ AC Adapter: B-EP800-AC-QM-R
 - ◆ Cigarette lighter adapter: B-EP802-DC12-QM-R
 - ◆ DC adapter: B-EP800-DC48-QM-R

DO NOT CONNECT any device other than the above to the printer.

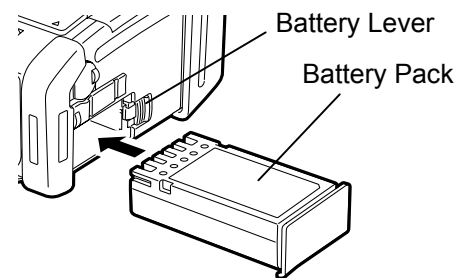

[B-EP2DL Series]

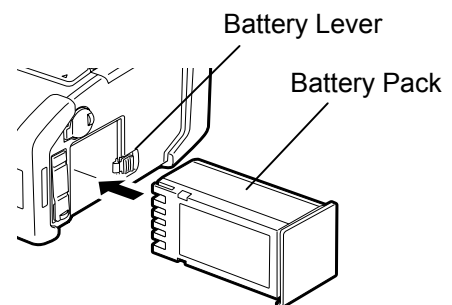

[B-EP4DL Series]

Removing a battery pack

Slide the Battery Lever in the direction of the arrow, and remove the Battery Pack from the printer.

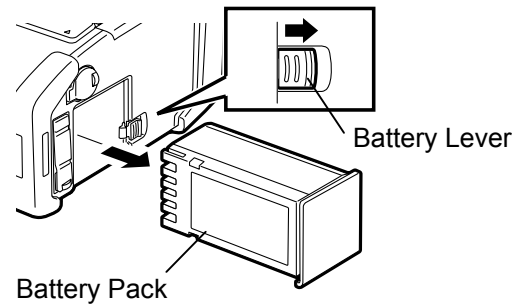

[B-EP2DL Series]

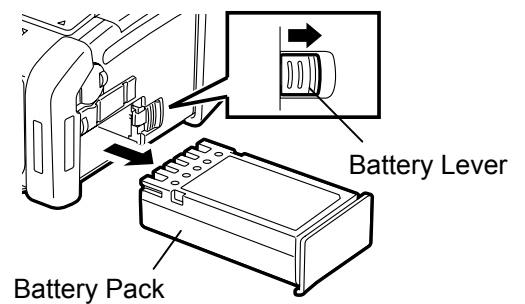

[B-EP4DL Series]

Charging the Battery Pack with an Optional Adapter

When charging the battery pack in the printer using an optional AC Adapter, cigarette lighter adapter, or DC adapter, insert the plug of the adapter into DCIN Connector of the printer.

Notice

For details, please refer to the Owner's Manual of respective optional adapters.

When using an optional battery charger to charge the battery packs, please refer to the Owner's Manual of respective models of battery charger.

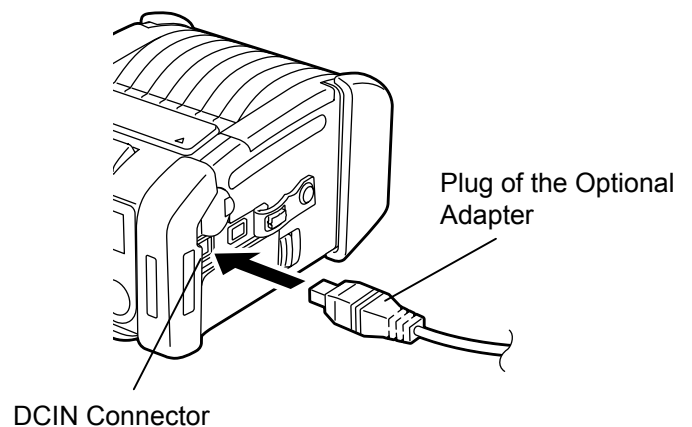

Loading the Media

1. Press the Top Cover Open Button to open the Top Cover.

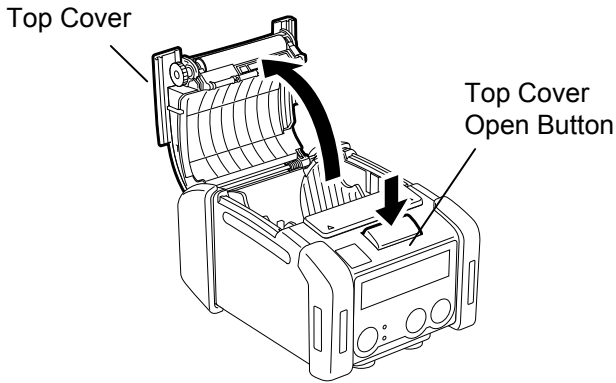

[B-EP2DL Series]

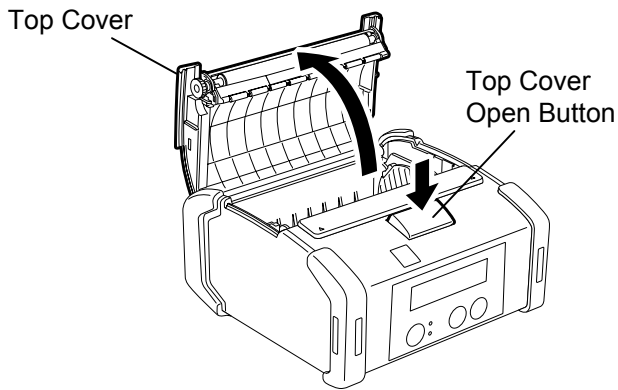

[B-EP4DL Series]

2. Move the Paper Guide Lever toward the Operation Panel and the Paper Guides outward.

3. Place a media roll in the printer.

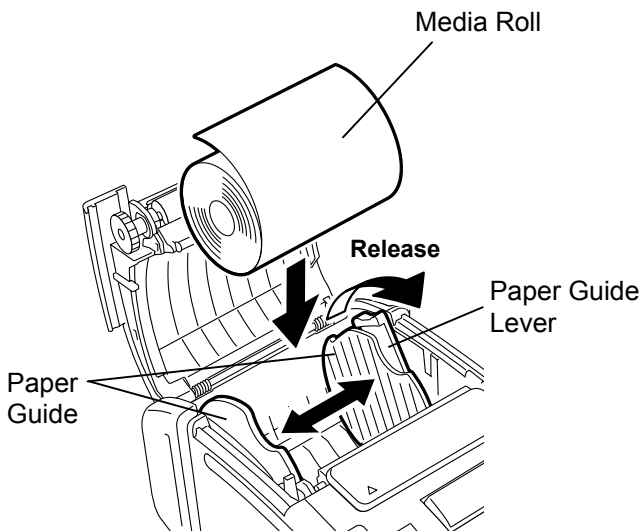

4. Adjust the Paper Guides to the media roll width.

5. Push back the Paper Guide Lever to lock the Paper Guides.

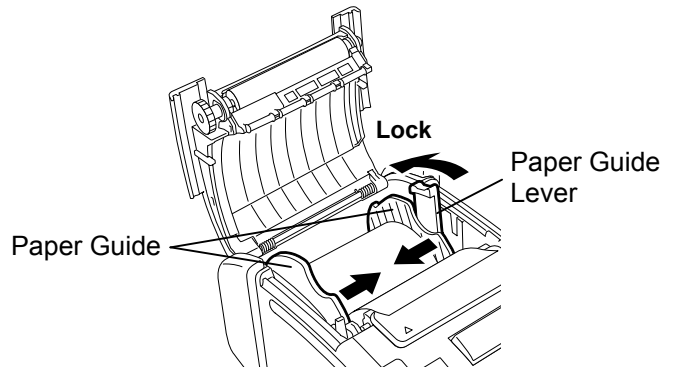

6. Pull the top edge of the media toward the Operation Panel, and close the Top Cover removing slack of the media.

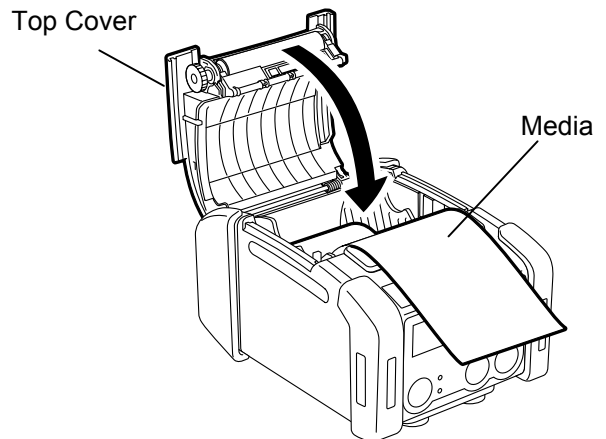

Notice

- Please use TOSHIBA TEC approved media only. We are not responsible for any print result caused by use of other media
- When you order media, please contact the nearest TOSHIBA TEC representative.

Before using a peel-off unit

When issuing labels in the peel-off mode, pull out the peel-off roller before loading a label roll.

Open the Top cover, and push the Peel-off Cover by the ▲ marks with your thumbs in the direction of the arrow.

Pull the Peel-off Roller until it clicks. Refer to "Loading the Media" on the previous page and set a label roll.

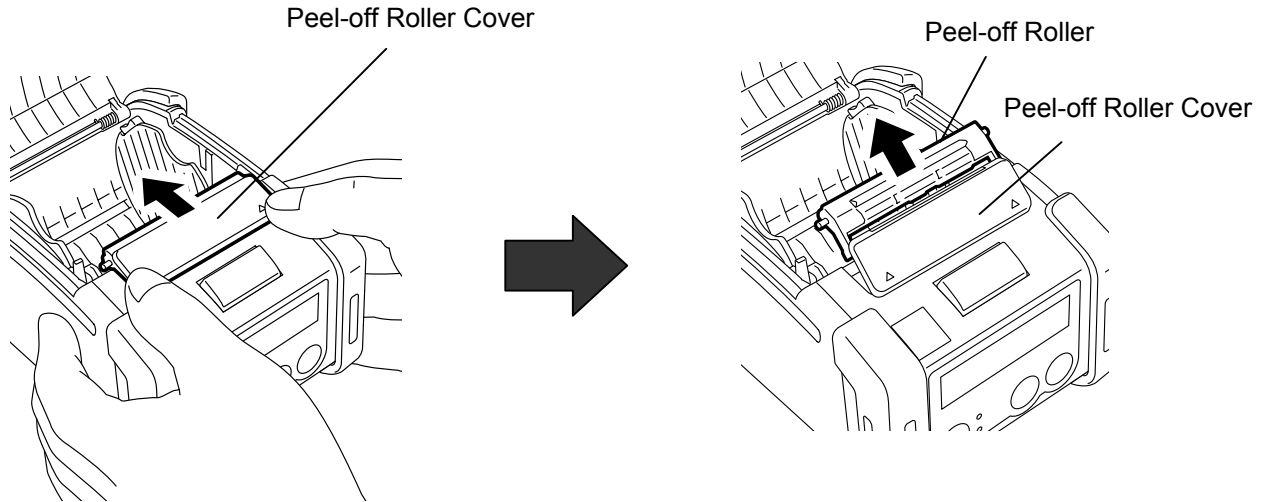

Notice

For the B-EP4DL series, DO NOT PULL the center of the Peel-off roller hard. Doing so may break the Peel-off roller.

■ How to put back the Peel-off Roller

Slightly hold down the Peel-off Roller Cover, and insert the Peel-off Roller under the Peel-off Roller Cover.

Push the Peel-off Roller Cover into the printer in the direction indicated by the arrow until it clicks.

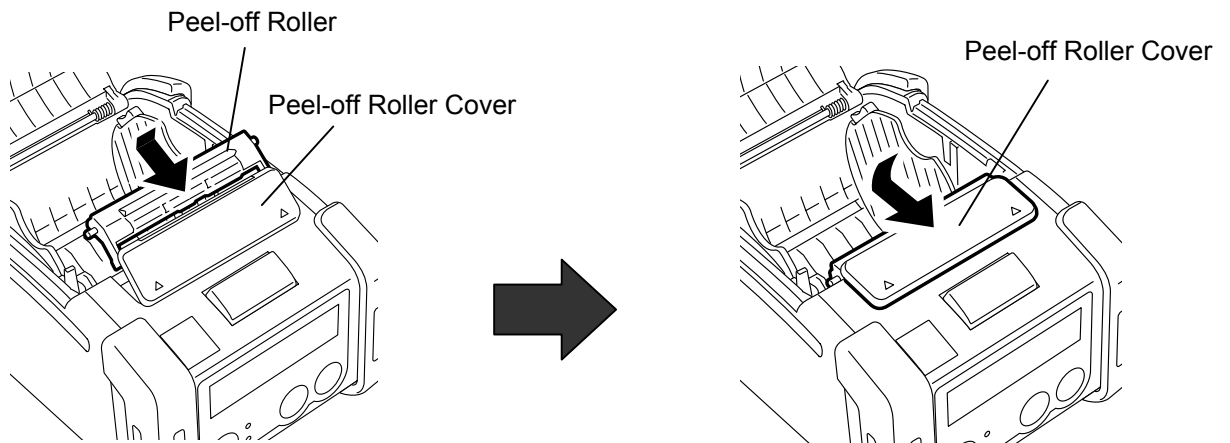

How to attach the accessories

CAUTION!

Care should be taken not to drop the printer when securing it to your waist.

■ Belt Clip

When you use the printer fixing to your belt, secure the supplied Belt Clip to the printer back.

1. Secure the Belt Clip to the printer back with the two screws.

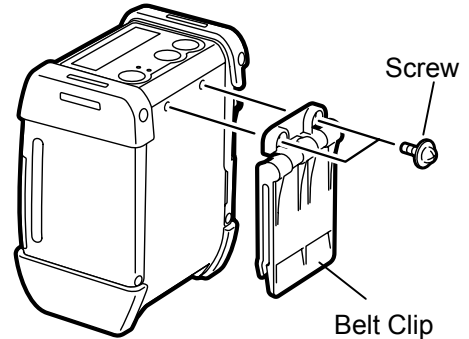

2. Fasten the Belt Clip to your belt.

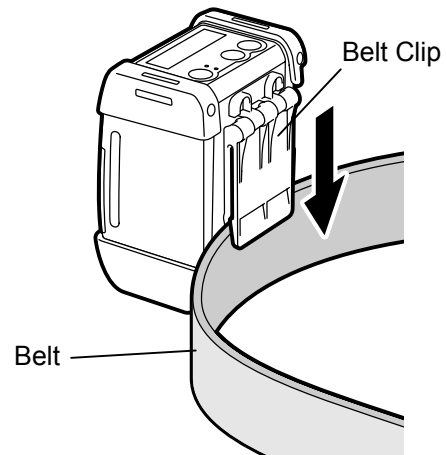

■ Shoulder Strap (Option)

Use the following procedure to fasten an optional shoulder strap (B-EP900-SS-QM-R) to the printer.

1. Pass either end of the Shoulder Strap through the Strap Slot of the printer, as shown in the figure below.
2. Pass the end of the Shoulder Strap through the buckle. Slide the buckle to adjust the Shoulder Strap length.
3. Do the same to the other end of the Shoulder Strap.

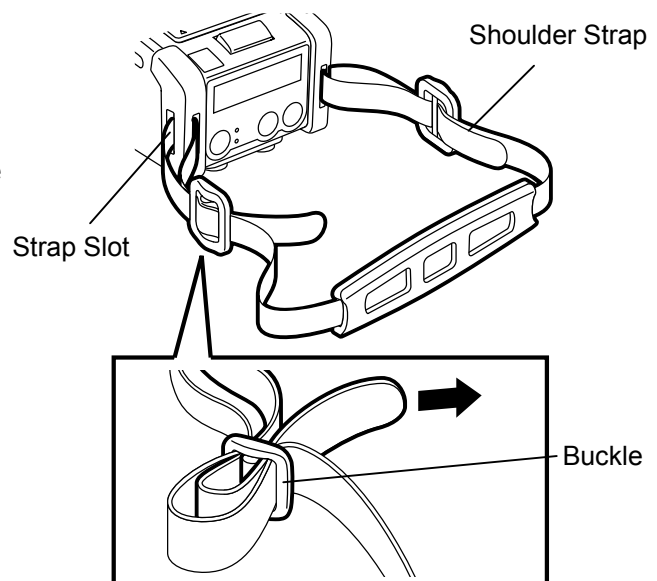

■ Carry case (Option)

A carry case exclusively for the printer is available as an option.

B-EP2DL Series: B-EP902-CC-QM-R

B-EP4DL Series: B-EP904-CC-QM-R

Put the printer into the Carry Case using the following procedure.

1. Turn off the printer.
2. Put the printer into the Carry Case in the orientation indicated by the illustration on the right.

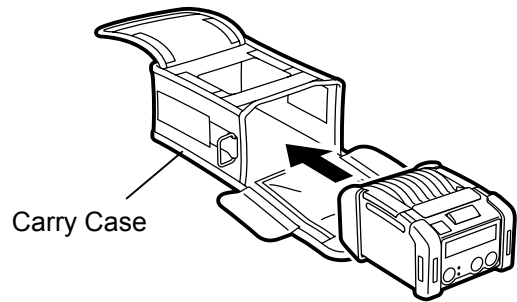

Notice

Before putting the printer into the Carry Case, remove the Belt Clip, if it has been attached.

3. Close the Media Outlet Flap and the Top Flap of the Carry Case.

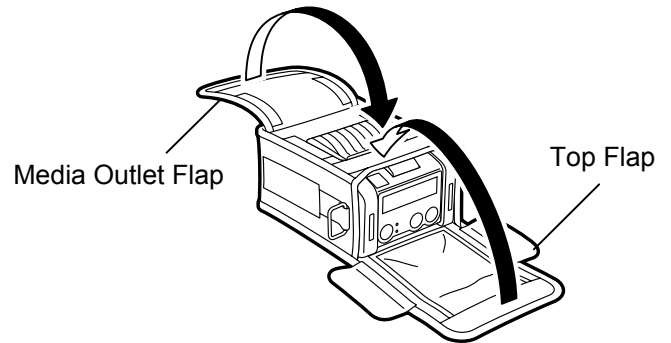

Notice

When issuing the media, please be sure to open the Media Outlet Flap. Failure to do this may cause a paper jam.

4. Pass either end of the Shoulder Strap supplied with the Carry Case through the ring of the Carry Case.
5. Pass the end of the Shoulder Strap through the buckle. Slide the buckle to adjust the Shoulder Strap length.
6. Do the same to the other end of the Shoulder Strap.

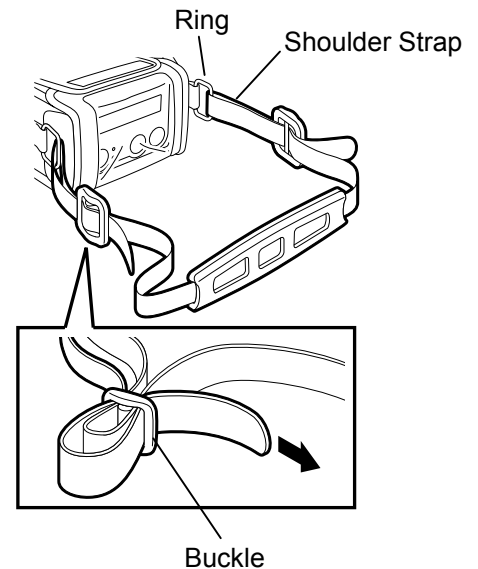

CARE/HANDLING OF THE MEDIA

CAUTION!

Be sure to read carefully and understand the Supply Manual. Use only media that meets specified requirements. Use of non-specified media may shorten the head life and result in problems with bar code readability or print quality. All media should be handled with care to avoid any damage to the media or printer. Read the following guideline carefully.

- Do not store the media for longer than the manufactures recommended shelf life.
- Store media rolls on the flat end, do not store them on the curved sides as this might flatten that side causing erratic media advance and poor print quality.
- Store the media in plastic bags and always reseal after opening. Unprotected media can get dirty and the extra abrasion from the dust and dirt particles will shorten the print head life.
- Store the media in a cool, dry place. Avoid areas where they would be exposed to direct sunlight, high temperature, high humidity, dust or gas.
- The thermal paper used for direct thermal printing must not have specifications which exceed Ca⁺⁺ 800 ppm, Na⁺ 800 ppm, K⁺ 800 ppm and Cl⁻ 600 ppm.
- Some ink used on pre-printed labels may contain components which shorten the print head's product life. Do not use labels pre-printed with ink which contains hard substances such as carbonic calcium (CaCO₃) and kaolin (Al₂O₃, 2SiO₂, 2H₂O).

For further information please contact your local distributor or your media manufacturer.

Data Transmission

■ IrDA

1. Place the printer close to the host so that their IrDA windows face each other within 10 cm distance.
2. Turn on the printer and the host, and send data from the host to the printer.

Notice

While communicating, avoid location where the IrDA window is subjected to direct sunlight. A communication failure may occur.

Supplement

- To communicate with the host via IrDA, it is required to configure the printer settings on the host.
- Communicable distance and angle is shown in the figure on the right. Note that this performance is obtained under 1000 lux or less of fluorescent lamp light.

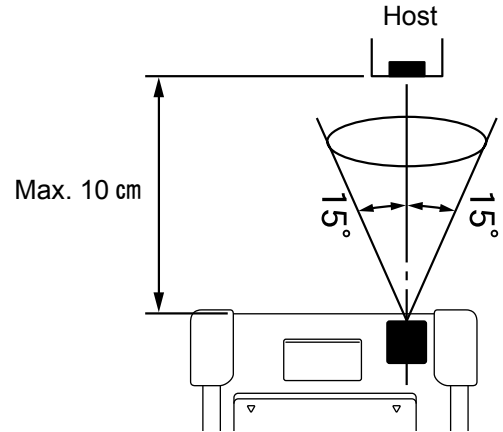
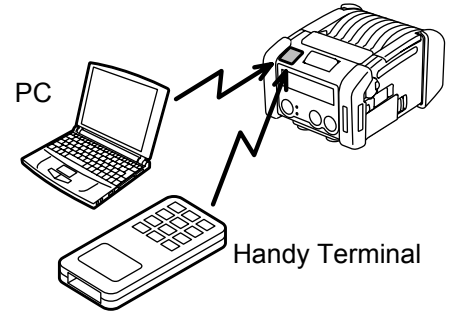

■ USB

1. Turn on the host and start the system.
2. Turn on the printer and connect a USB cable to the printer.
3. Connect the USB cable to the host.
4. Send data from the host to the printer.

Notice

- For details of the interface cable, please consult the nearest TOSHIBA TEC representative.
- When disconnecting the USB cable, please follow the instruction of the system on the host.

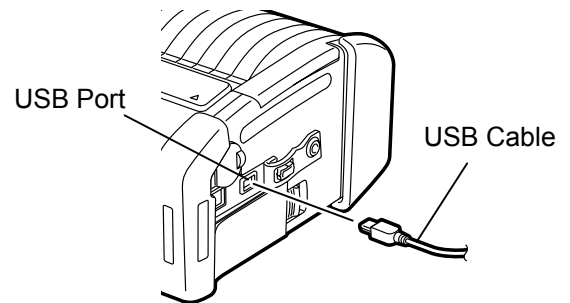

■ Serial (RS-232C) (GH20 model only)

1. Connect the serial interface cable to the RS-232C port on the printer.
2. Connect the other end of the serial interface cable to the host.
3. Turn on the printer and the host, and send data from the host to the printer.

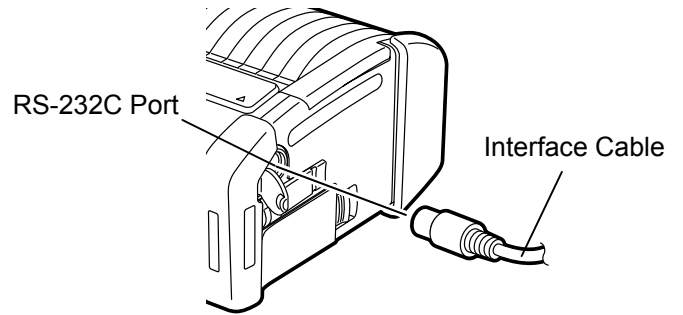

Notice

For details of the interface cable, please consult the nearest TOSHIBA TEC representative.

■ Wireless (GH30/GH40 model only)

1. In the case of Bluetooth, place the printer within 3 m from the host.
In the case of wireless LAN, place the printer within a wireless coverage area.
2. Turn on the printer and the host, and send data from the host to the printer.

Notice

- Please be sure to read "Precautions for Handling of Wireless Communication Devices" before operating the printer.
- Confirm that there is no obstacles between the printer and the host. Obstacles may cause a communication failure.

Supplement

The radio connectivity is affected by the operating environment. Especially, metal obstacles, metal powder, or locations enclosed by metal walls may prevent proper communication. For the installation location of access points, please consult the nearest TOSHIBA TEC representative.

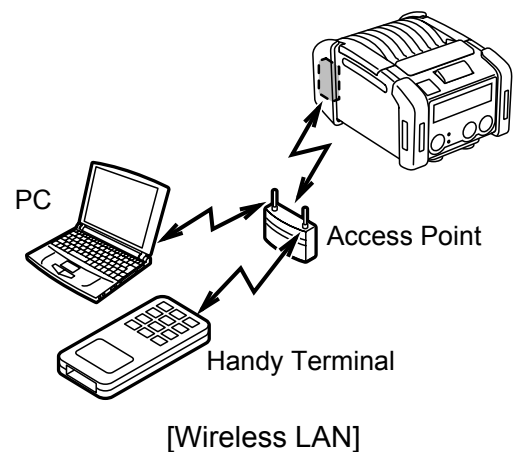
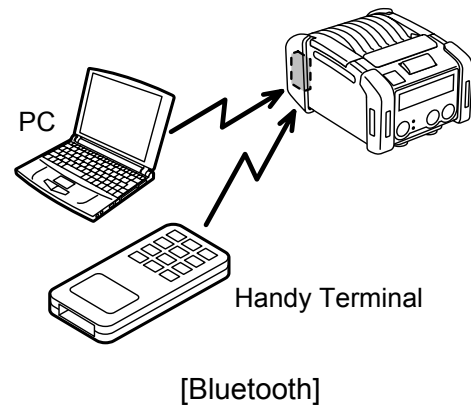

Daily maintenance

To help retain the high quality and performance of your printer, it should be cleaned regularly.

■ Print head

Wipe the print head element with a supplied print head cleaner pen.

CAUTION!

- *DO NOT USE a sharp object to clean the print head, as this may cause a print failure or breakdown of the printer.*
- *NEVER USE any volatile solvent including thinner and benzene, as this may cause a print failure or breakdown of the printer.*
- *Do not touch the print head element with bare hands, as static may damage the print head.*

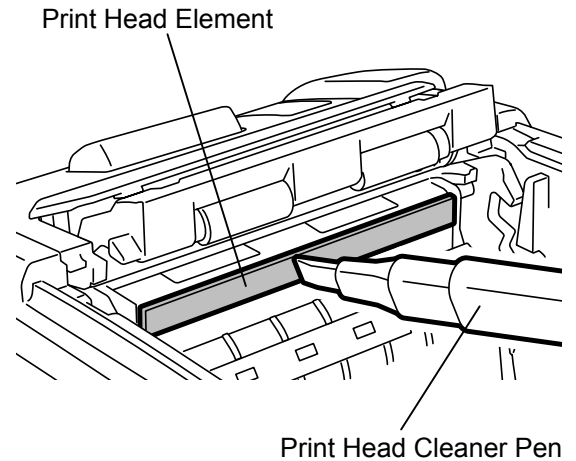

■ Peel-off roller

Wipe clean the Peel-off Roller with a soft cloth slightly moistened with absolute ethyl alcohol while rotating the rollers.

CAUTION!

- *NEVER USE any volatile solvent including thinner and benzene, as this may cause a peel-off failure or deterioration of the Peel-off Roller.*

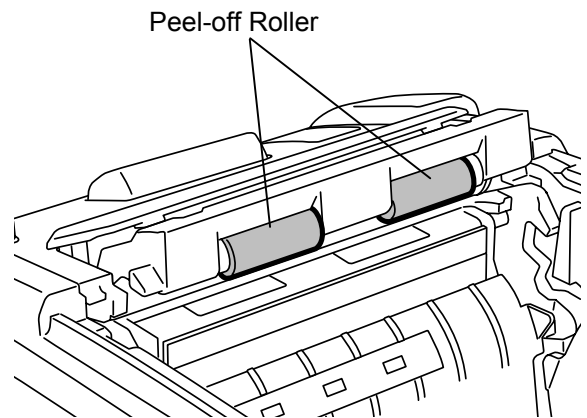

■ Platen

Wipe clean the platen with a soft cloth slightly moistened with absolute ethyl alcohol, while rotating the platen.

Clean the platen of the linerless label kit in the same way. Cleaning should be performed each time one or two media rolls are used up.

CAUTION!

- *Do not damage the platen with a sharp object, as this may cause a print failure or printer trouble.*
- *NEVER USE any volatile solvent including thinner and benzene, as this may cause a print failure or deterioration of the Platen.*

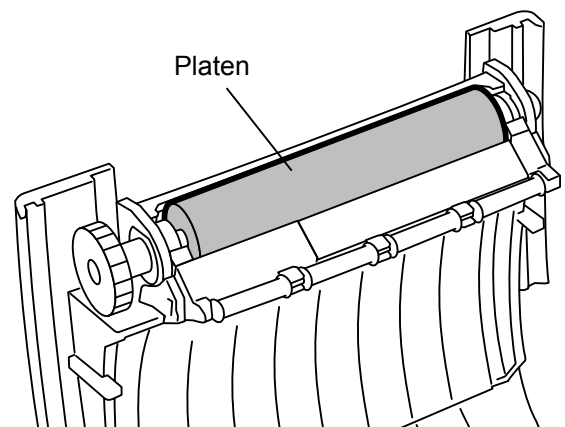

■ Media Guide Roller and Strip Shaft

Wipe clean the Media Guide Rollers with a soft cloth moistened with absolute ethyl alcohol while rotating the rollers.

Wipe clean the strip shaft with a soft cloth slightly moistened with absolute ethyl alcohol.

Clean the strip shaft of the linerless label kit in the same way. Cleaning should be performed each time one or two media rolls are used up

CAUTION!

NEVER USE any volatile solvent including thinner and benzene, as this may cause deterioration of the Paper Guide Roller.

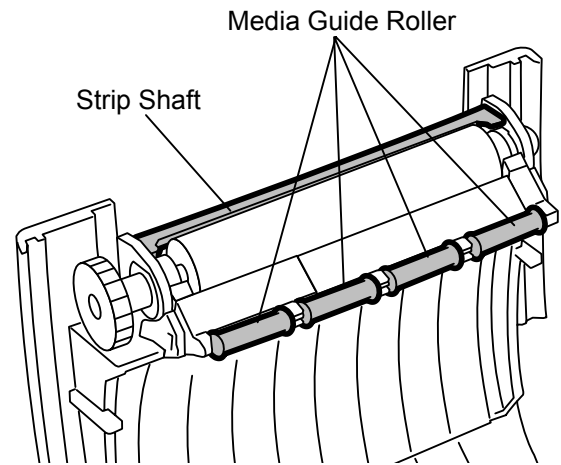

■ Media Sensor Window and Media Path

Remove dust or dirt from the Media Sensor Window with a commercially available soft, dry brush.

Wipe clean the Media Path with a slightly moistened soft cloth.

When linerless labels are used, wipe off dirt of residual glues from the Media Guides each time one or two media rolls are used up.

CAUTION!

NEVER USE any volatile solvent including thinner and benzene, as this may cause feed failure or deterioration of the printer.

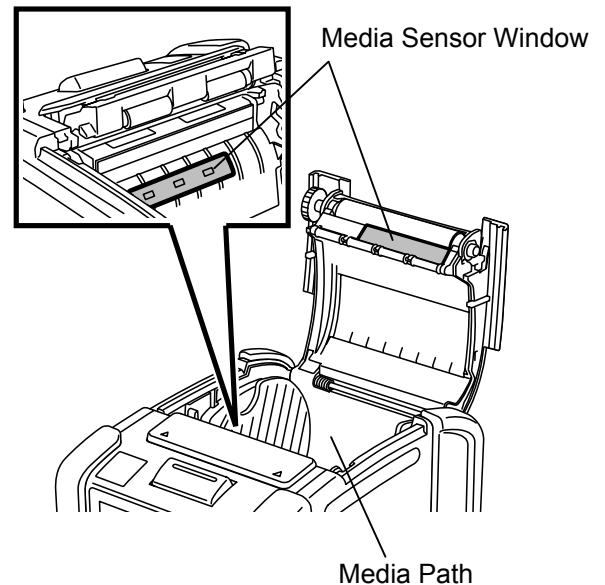

■ Top Cover, Operation panel, and IrDA Window

Wipe clean the cover, operation panel, and IrDA window with a soft dry cloth slightly moistened with absolute ethyl alcohol.

Remove any dirt or residual glues from the media outlet with a cotton swab slightly moistened with absolute ethyl alcohol.

When linerless labels are used, wipe off dirt of residual glues from the Top Cover or Media Outlet each time one or two media rolls are used up.

CAUTION!

NEVER USE any volatile solvent including thinner and benzene, as this may cause discoloration or deterioration of the printer.

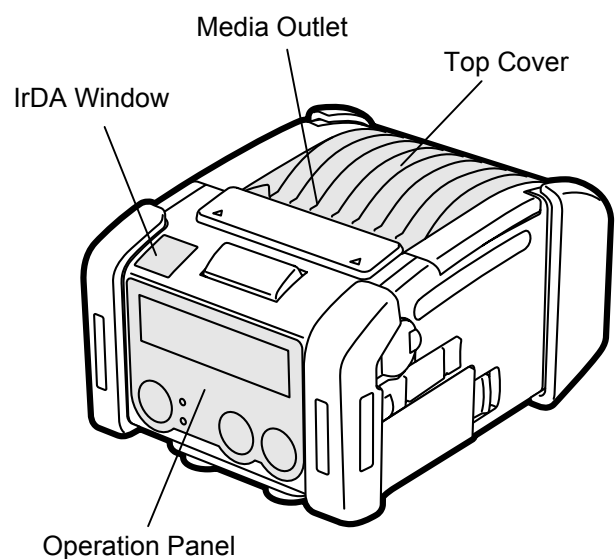

Troubleshooting

When a problem occurs during operation, please check the following troubleshooting guide and take corrective action.

If you cannot solve a problem with the following solutions, do not attempt to repair it by yourself. Turn off the printer, remove the battery pack, then contact a TOSHIBA TEC service representative for assistance.

If an error message is displayed.

When an error message is displayed, follow the respective instruction, then press the [PAUSE] button. The error will be cleared.

Error Message	Cause	Solution
COMMS ERROR	A parity error or framing error has occurred during communication by RS-232C.	Turn off the [POWER] button, then back to on. Send data from the host to the printer again. If the problem recurs, please turn off the power and contact TOSHIBA TEC service representative.
PAPER JAM ****	The media is not loaded properly.	Load the media properly.
	The media is jammed in the printer.	Remove the jammed media, and load the media properly. Press the [PAUSE] button.
	The media is not fed properly.	Load the media properly and press the [PAUSE] button.
	The reflective sensor does not detect black marks .	Load the media properly.
	The transmissive sensor does not detect gaps between labels.	Load the media properly. If the problem recurs, set a threshold again.
NO PAPER ****	The printer ran out of media.	Load a new media roll and press the [PAUSE] button.
COVER OPEN ****	The top cover is opened.	Close the top cover.
HEAD ERROR	A part of the print head element is broken.	Turn off the printer and contact TOSHIBA TEC service representative for replacement of the print head.
FLASH WRITE ERR.	A flash memory write error occurred.	Turn off the [POWER] button, then back to on. Send data from the host to the printer again. If the problem recurs, please turn off the power and contact TOSHIBA TEC service representative.
FORMAT ERROR	A flash memory format error occurred.	Turn off the [POWER] button, then back to on. Send data from the host to the printer again. If the problem recurs, please turn off the power and contact TOSHIBA TEC service representative.

Error Message	Cause	Solution
FLASH MEM FULL	The flash memory has insufficient area for storing data.	Turn off the [POWER] button, then back to on. Send data from the host to the printer again. If the problem recurs, please turn off the power and contact TOSHIBA TEC service representative.
LOW BATTERY	Remaining battery capacity is low.	Turn off the printer, and replace the battery pack with a fully charged one.
EXCESS HEAD TEMP	The print head temperature reached the upper limit of the operating temperature.	Stop printing and wait until the printer automatically restores. If the problem recurs, please turn off the power and contact TOSHIBA TEC service representative.
Command error example PC001;0A00,0300,	When a command error occurs, up to 16 digits of alphanumeric or symbol are displayed on the upper line of the LCD.	Turn off the [POWER] button, then back to on. Send data from the host to the printer again. If the problem recurs, please turn off the power and contact TOSHIBA TEC service representative.
Other error messages	A hardware or software failure occurs.	Turn off the [POWER] button, then back to on. If the problem recurs, please turn off the power and contact TOSHIBA TEC service representative.

****: The number of unprinted labels 1 to 9999 (in units of label)

When the printer does not operate properly

In the case of the following symptoms, please check the respective points and take corrective action.

Symptom	Point to check (Cause)	Solution
The printer does not turn on by pressing the POWER switch.	The battery pack is not loaded correctly.	Load a fully charged battery pack correctly.
Fully charged battery is loaded but the operating time is short.	The battery life is expired.	Load a fully charged new battery pack correctly.
The printer cannot communicate via IrDA.	The printer is not turned on.	Turn on the printer.
	Distance to the host is too far. .	Bring the printer close to the host so that their IrDA windows face each other within 10cm.
	Angle of the IrDA window is not proper.	Move the printer so that the IrDA window face that of the host.
	Direct sunlight is coming into the IrDA window	Avoid direct sunlight.
	IrDA window is dirty.	Clean the IrDA window.
	Serial interface cable is connected. (GH20 only)	Disconnect the RS-232C cable from the printer.
	The printer is communicating via wireless communication. (GH30/GH40 only)	Terminate the wireless communication.
Communication conditions are incorrect.	Set the communication conditions correctly	

Symptom	Point to check (Cause)	Solution
	Issue mode is incorrect.	Select a correct issue mode.
	Transmission speed is incorrect.	Send data at correct transmission speed.
The printer cannot communicate via USB.	The printer is not turned on.	Turn on the printer.
	Serial interface cable is connected. (GH20 only)	Disconnect the RS-232C cable from the printer.
	The printer is communicating via wireless communication. (GH30/GH40 only)	Terminate the wireless communication.
	Issue mode is incorrect.	Select a correct issue mode.
The printer cannot communicate via serial interface (GH20 only)	The printer is not turned on.	Turn on the printer.
	The interface cable is not connected properly.	Completely connect the interface cable.
	Issue mode is incorrect.	Select a correct issue mode.
	Transmission speed is incorrect.	Send data at correct transmission speed.
The printer cannot communicate via Bluetooth. (GH30 only)	The printer is not turned on.	Turn on the printer.
	Distance to the host is too far.	Bring the printer close to the host within 3 m.
	The printer is used in a location where it is subjected to noise or interference.	Avoid such location.
	The printer address is not correctly set on the host.	Correctly set the print address on the host.
	Issue mode is incorrect.	Select a correct issue mode.
The printer cannot communicate via wireless LAN. (GH40 only)	The printer is not turned on.	Turn on the printer.
	Distance to the host is too far.	Bring the printer within a wireless coverage area.
	Obstacles block the radio wave.	Use the printer in a location with no obstacles.
	The printer is used in a location where it is subjected to noise or interference.	Avoid such location.
	The printer address is not correctly set on the host.	Correctly set the print address on the host.
	Channel setting for the access point or host is incorrect.	Avoid using a channel which interferes with adjacent access points.
	Issue mode is incorrect.	Select a correct issue mode.
Printout is too light.	The print head is dirty.	Clean the print head.
	The media is not loaded properly.	Load the media properly.
	Deteriorated media is used.	Load a new media roll.
	The media is not a TOSHIBA TEC approved one	Use TOSHIBA TEC approved media.
The printer received print data but does not print.	The STATUS lamp is lit or blinking.	Clear the error
	The media is not loaded properly.	Load the media properly.

Printer Specification

B-EP2DL Series

Model	B-EP2DL-GH20-QM-R	B-EP2DL-GH30-QM-R	B-EP2DL-GH40-QM-R
Driving power source	Lithium ion battery 7.4V 2600mAh (Nominal value) (Battery pack model name: B-EP802-BT-QM-R)		
Printable count	Max. nn/Full charge (It depends on the operating environment, print conditions, etc.)		
Life cycle	300 cycles		
Print method	Direct thermal		
Resolution	8 dots/mm (203 dpi)		
Print speed	Approx. 12.5 mm/sec. to 105.0 mm/sec. (It depends on the operating environment, print conditions, etc.)		
Issue mode	Peel-off/Batch		
Effective print width	Max. 48.0mm		
Font	[Bitmap Font] Times Roman, Helvetica, Presentation, Letter Gothic, Prestige Elite, Courier, OCR-A, OCR-B, GOTHIC725Black, Standard character, Bold character, Price font1, Price font 2, Chinese character, Writable character [Outline font] Helvetica (w/wo Proportional), Price font 1, Price font 3, Price font 3		
Bar code	JAN8/EAN8, JAN13/EAN13, UPC-A/E, CODE39, CODE93, CODE128 (EAN128), MSI, NW-7, ITF, Customer bar code, GS1 Databar (Omnidirectional/Truncated/Stacked/Stacked Omnidirectional/Limited/ Expanded/Expanded Stacked)		
2-dimensional code	QR code, Data Matrix, PDF417, Maxicode, MicroPDF417		
Media detection sensor	Transmissive/Reflective/Peel-off		
Interface			
IrDA (IrDA V1.2 Low Power)	○	○	○
USB (V2.0)	○	○	○
Serial (RS-232C)	○	X	X
Bluetooth(V1.2)	X	○	X
Wireless LAN (IEEE802.11b/g)	X	X	○
Operating temperature	-15°C to 50°C		0°C to 50°C
	(During battery charge: 0°C to 40°C/LCD display: 0°C to 50°C)		
Operating humidity	10%RH to 90%RH (No condensation)		
Storage temperature	-25°C to 60°C		
Storage humidity	10%RH to 90%RH (No condensation)		
Dimensions (Unit: mm)	88.0 (W) x 119.0 (L) x 65.0 (D) (Excluding the projecting parts.)		
Weight	Approx. 450 g (Battery pack included, media excluded.)		Approx. 460 g (Battery pack included, media excluded.)
Accessories	Battery pack x 1, Print head cleaner x 1, Belt clip x 1, Belt clip mounting screw x 2 pcs., Owner's Manual x 1		
Option	Single-slot battery charger (B-EP800-CHG-QM-R), 6-slot battery charger (B-EP800-CHG6-QM-R), AC adapter (B-EP800-AC-QM-R), Cigarette lighter adapter (B-EP802-DC12-QM-R), DC adapter (B-EP800-DC48-QM-R), Battery pack (B-EP802-BT-QM-R), Linerless Label kit (B-EP902-LL-QM-R), Shoulder strap (B-EP900-SS-QM-R), Carry case (B-EP902-CC-QM-R)		

Supplement

Specification of this printer may be changed without prior notice.

B-EP4DL-R Series

Model	B-EP4DL-GH20-QM-R	B-EP4DL-GH30-QM-R	B-EP4DL-GH40-QM-R
Driving power source	Lithium ion battery 14.8V, 2600mAh (Nominal value) (Batter pack model name: B-EP804-BT-QM-R)		
Printable count	Max. nn /Full charge (It depends on the operating environment, print conditions, etc.)		
Life cycle	300 cycles		
Print method	Direct thermal		
Resolution	8 dots/mm (203 dpi)		
Print speed	Approx. 12.5 mm/sec. to 105.0 mm/sec. (It depends on the operating environment, print conditions, etc.)		
Issue mode	Peel-off/Batch		
Effective print width	Max. 104.0 mm		
Font	[Bitmap Font] Times Roman, Helvetica, Presentation, Letter Gothic, Prestige Elite, Courier, OCR-A, OCR-B, GOTHIC725 Black, Standard character, Bold character, Price font 1, Price font 2, Chinese character, Writable character [Outline font] Helvetica (w/wo proportional), Price font 1, Price font 2, Price font 3		
Bar code	JAN8/EAN8, JAN13/EAN13, UPC-A/E, CODE39, CODE93, CODE128 (EAN128), MSI, NW-7, ITF, Customer bar code, GS1 Databar (Omnidirectional/Truncated/Stacked/Stacked Omnidirectional/Limited/Expanded/Expanded Stacked)		
2-dimensional code	QR code, Data Matrix, PDF417, Maxicode, MicroPDF417		
Media detection sensor	Transmissive/Reflective/Peel-off		
Interface			
IrDA (IrDA V1.2 Low power)	○	○	○
USB (V2.0)	○	○	○
RS-232C	○	X	X
Bluetooth (V1.2)	X	○	X
Wireless LAN (IEEE802.11b/g)	X	X	○
Operating temperature	-15°C to 50°C		0°C to 50°C
	(During battery charge: 0°C to 40°C/LCD display: 0°C to 50°C)		
Operating humidity	10%RH to 90%RH (No condensation)		
Storage temperature	-25°C to 60°C		
Storage humidity	10%RH to 90%RH (No condensation)		
Dimensions (Unit: mm)	150.0 (W) x 145.0 (L) x 75.0 (D) (Excluding the projecting parts.)		
Weight	Approx. 820 g (Battery pack included, media excluded.)		Approx. 830 g (Battery pack included, media excluded.)
Accessories	Battery pack x1, Print head cleaner x 1, Belt clip x1, Belt clip mounting screw x 2 pcs., Owner's Manual x1		
Option	Single-slot battery charger (B-EP800-CHG-QM-R), 6-slot battery charger (B-EP800-CHG6-QM-R), AC adapter (B-EP800-AC-QM-R), DC adapter (B-EP800-DC48-QM-R), Battery pack (B-EP804-BT-QM-R), Linerless label kit (B-EP904-LL-QM-R), Shoulder strap (B-EP900-SS-QM-R), Carry case (B-EP904-CC-QM-R)		

Supplement

Specification of this printer may be changed without prior notice.

English

The following information is for EU-member states only:

Disposal of products

(based on EU-Directive 2002/96/EC,

Directive on Waste electrical and electronic equipment – WEEE)



The use of the symbol indicates that this product may not be disposed as unsorted municipal waste and has to be collected separately. Integrated batteries and accumulators can be disposed of with the product. They will be separated at the recycling centers.

The black bar indicates that the product was placed on the market after August 13, 2005.

By ensuring this product is disposed of correctly, you will help prevent potential negative consequences for the environmental and human health, which could otherwise be caused by inappropriate waste handling of this product.

For more detailed information about the take-back and recycling of this product, please contact your supplier where you purchased this product.

Français

Les informations suivantes ne concernent que les utilisateurs des pays membres de l'union Européenne :

Recyclage des produits

(Basé sur la directive Européenne 2002/96/EC,

Directive sur le recyclage des équipements électriques et électroniques - WEEE)



L'utilisation de ce symbole indique que ce produit ne doit pas être jeté sans tri préalable, comme un déchet classique, mais doit être collecté séparément. Les batteries et accumulateurs intégrés peuvent être laissés en place, ils seront récupérés par le centre de recyclage.

La barre noire indique que ce produit a été mis sur le marché après le 13 Août 2005.

En vous assurant que ce produit est correctement mis au rebut, vous participerez à prévenir les éventuelles conséquences néfastes sur l'environnement et la santé publique qui pourraient autrement être causés par une gestion inappropriée des déchets contenus dans ce produit.

Pour obtenir des informations complémentaires sur la récupération et le recyclage de ce produit, veuillez contacter le fournisseur auprès duquel vous en avez fait l'acquisition.

Deutsch

Wiederverwertungsinformationen für Verbraucher:

(gemäß EU-Directive 2002/96/EC,

Directive on Waste electrical and electronic equipment – WEEE)



Die folgenden Informationen gelten nur für EU-Mitgliedsstaaten.

Das durchgestrichene Mülltonnensymbol weist darauf hin, dass dieses Produkt nicht wie allgemeiner Hausmüll behandelt werden darf. Verbaute Batterien oder Akkus müssen vorher entnommen und separat entsorgt werden.

Der schwarze Balken unter dem Symbol besagt, dass das Produkt nach dem 13. August 2005 in Verkehr gebracht wurde.

Indem Sie aktiv mit helfen, dieses Produkt ordnungsgemäß zu entsorgen, helfen Sie mit mögliche negativen Auswirkungen auf die Umwelt sowie die menschliche Gesundheit zu vermeiden.

Für nähere Informationen zur Rücknahme und Wiederverwertung dieses Produktes wenden Sie sich bitte an Ihren Lieferanten.

Español

La siguiente información solo concierne a los Estados Miembros de la UE:

Desechado de los productos

(basado en la Directiva Europea 2002/96/EC,

Directiva sobre Residuos de equipos eléctricos y electrónicos – WEEE)



El uso de este símbolo indica que el producto no puede ser desechado como basura común doméstica por lo que debe ser recogido de forma separada. Sus baterías y acumuladores integrados pueden eliminarse junto con el aparato. Estos elementos serán separados en los centros de reciclado.

La barra negra indica que el producto fue puesto en el Mercado después del 13 de Agosto de 2005. Asegurando que nos deshacemos del producto de forma correcta, ayudaremos a evitar potenciales consecuencias negativas tanto para el medio ambiente como para la salud pública, que podrían producirse debido a un tratamiento inapropiado.

Para obtener información más detallada sobre la recogida y reciclaje de su producto, por favor, póngase en contacto con el proveedor que se lo suministró.

Nederlands

Onderstaande informatie geldt enkel in EU lidstaten:

Het afdanken van producten (volgens EU-richtlijn 2002/96/EC,

Richtlijn betreffende afgedankte elektrische en elektronische apparatuur WEEE)



Dit symbool geeft aan dat dit product niet mag afgedankt worden als algemeen huishoudelijk afval. Het dient afzonderlijk gecollecteerd te worden. Geïntegreerde batterijen of laders kunnen samen met dit product afgedankt worden. Zij worden in het recyclagecentrum gescheiden. De zwarte balk geeft aan dat dit product na 13 augustus 2005 verhandeld werd.

Door een aangepaste afdanking van dit product beschermt u het milieu en de volksgezondheid tegen mogelijke schadelijke gevolgen, die anders zouden kunnen voortvloeien uit het onjuist verwerken van de resten van dit product. Vraag inlichtingen over de terugname en recyclage van dit product aan uw leverancier.

Italiano

Le seguenti informazioni sono solo gli stati membri della UE:

Smaltimento del prodotto

(basato sulla direttiva EU-Directive 2002/96/EC,

Direttiva sullo smaltimento per il Riciclaggio delle Apparecchiature Elettriche od Elettroniche – RAEE – WEEE)



Questo simbolo indica che i prodotti non possono essere smaltiti come rifiuti urbani non differenziati ma devono essere raccolti separatamente. Eventuali batterie o accumulatori possono essere smaltiti con il prodotto. Verranno separati dai centri di riciclaggio

La barra nera indica che il prodotto è stato inserito nel mercato dopo il 13 Agosto 2005

Assicuratevi che questo prodotto sia smaltito correttamente, contribuirete a prevenire potenziali conseguenze negative per l'ambiente e la salute umana, che potrebbero essere altrimenti causate da uno smaltimento improprio di questo prodotto.

Per maggiori dettagli sul riciclo, o su come rendere il prodotto, contattate il vostro fornitore

Português

A informação que se segue é apenas dirigida a países membros da UE:

Reciclagem de produtos (baseado na directive-UE 2002/96/EC,

Directiva sobre a reciclagem de resíduos de equipamentos eléctricos e electrónicos – REEE)



O uso deste símbolo indica que este produto não pode ser colocado nos pontos de recolha de lixo comum e deve ser recolhido separadamente. As baterias integradas e acumuladores podem ser entregues juntamente com o produto. Serão depois separados nos centros de reciclagem.

A barra negra indica que o equipamento foi colocado no mercado após 13 de Agosto de 2005.

Ao assegurar-se que este produto é tratado correctamente está a ajudar a prevenir potenciais consequências negativas para o ambiente e para a saúde humana, que poderiam ser causadas pelo inapropriado tratamento deste produto.

Para mais informação sobre a reciclagem e tratamento deste produto, contacte o seu fornecedor.

Polski

Informacje dla Państw członkowskich Unii Europejskiej:

Utylizacja urządzeń

(na podstawie dyrektywy Unii Europejskiej 2002/96/EC,

Dyrektywa dotycząca odpadów elektrycznych i elektronicznych – WEEE)



Użycie symbolu oznacza, że urządzenie nie może być traktowane jako niesegregowane odpady i musi być zebrane oddzielnie. Zintegrowane baterie i akumulatory mogą być utylizowane razem z urządzeniem. Zostaną one posegregowane w centrach utylizacji.

Czarny prostokąt oznacza, że urządzenie zostało wprowadzone na rynek po 13 sierpnia 2005.

Poprzez zastosowanie się do prawidłowych procedur utylizacji tego urządzenia, pomożecie Państwo ograniczyć potencjalne negatywne skutki dla środowiska i zdrowia ludzkiego, które mogłyby zaistnieć na skutek niewłaściwej utylizacji tego urządzenia.

W celu uzyskania dodatkowych informacji odnośnie zwrotu i utylizacji tego urządzenia prosimy o kontakt z punktem zakupu tego urządzenia.